

POSSIBILITA' DI LAVORO M3/M4
 OPTION OF M3/M4 WORKING
 ARBEITSMOEGlichkeit M3/M4

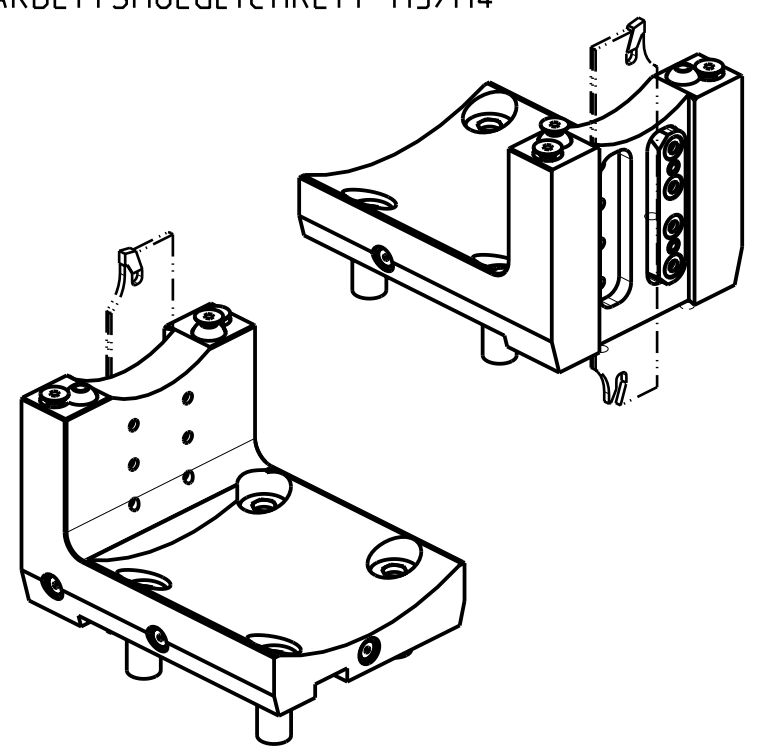

DOTAZIONI - SUPPLIED WITH - AUSSTATTUNG

- N°1 - LAMA - BLADE - KLINGE ISCAR H-32 Sp. 3/4mm (KENNAMETAL OPTIONAL)
- N°10 - INSERTI - INSERTS - EINLAGEN
- N°1 - CHIAVE A T PER MONTAGGIO INSERTI
 - T-WRENCH FOR INSERT SET UP
 - T-SCHLUESSEL FUER EINSATZSTUECK-MONTAGE

Cod. MT	N°Utensili N°Tools N°Werkzeuge	Reversibile lato mandrino/contromandrino Reversible sub/main spindle side Umkehrbare Spindel-seite/ Gegenspindel-seite	Lubr.esterna Ext. coolant Aussenkuehlung
OKU0230232	1	X	X

OKUMA
 MOD: LB2000-2500-3000EX(I) M/MY/MW/MYW - LB2000-2500-3000EX(II) M/MY/MW/MYW - LU3000EX M/MY/MW
 MULTUS U3000/4000/5000 2SW - GENOS L300MW/MYW - GENOS L3000e M/MY

PORTAUTENSILE RADIALE PER LAMA
 Radial blade holder
 Radial Abstechhalter

M.T. srl
 Via Casino Albini 480
 Tel. 0541/956034-957884
 Fax 0541/956341
 47842 S. GIOVANNI IN M. (RN)
 e-mail: mtma@mtmarchetti.com
 http://www.mtmarchetti.com



OKU510-4-00

Subject to change without notice.