

ATTENZIONE - ATTENTION - ACHTUNG

- NTJ100: solo per torretta superiore
- NTJ100: only on the upper turret
- NTJ100: nur auf dem oberen revolver

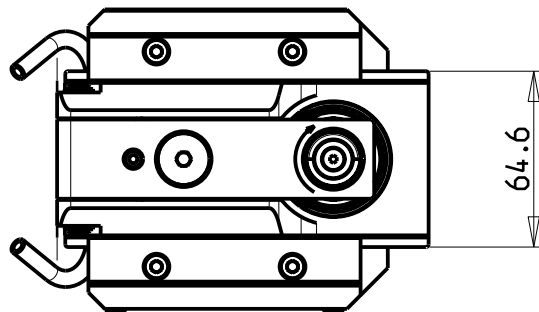
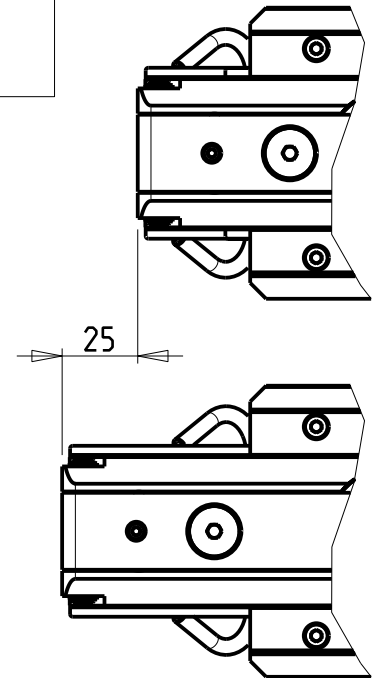
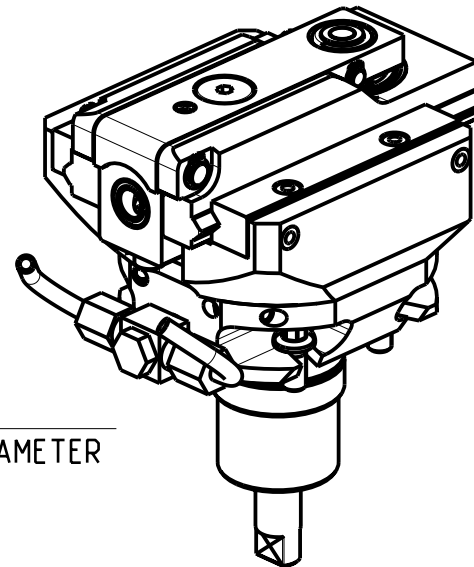

Ø16
TOOL DIAMETER

DOTAZIONI - SUPPLIED WITH - AUSSTATTUNG

N*1 Boccola di riduz. Ø16-Ø12 e N*1 Boccola di riduz. Ø16-Ø10
 N*1 Reduction bush Ø16-Ø12 and N*1 Reduction bush Ø16-Ø10
 N*1 Reduzierbuchsen Ø16-Ø12 und N*1 Reduzierbuchsen Ø16-Ø10

PER UTENSILI STOZZATORI VEDI PAG. TBL400-1-00
 FOR DRIVEN SLOTTING TOOL CUTTING-TOOLS SEE PAGE TBL400-1-00
 FÜR NUTENSTOSS-WERKZEUG SCHNEIDWERKZEUGE SIEHE SEITE TBL400-1-00

Cod. MT	I	RPM MAX	Reversibile lato mandrino/contromandrino Reversible sub/main spindle side Umkehrbare Spindel-seite/ Gegenspindel-seite	Lubr. esterna Ext. coolant Aussenkuehlung
NKM1210200	4:1	2400	X	X

NAKAMURA-TOME

MOD: WT100 - WY100 - WY100II 12ST. - WY100V 12ST. - SUPER NTY3 - NTY3-100 12ST. - NTJ100 - SC100 - SC100X²

MODULO MOTORIZZATO STOZZATORE CORSA 25mm H=65mm

Slotting driven tool 25mm stroke H=65mm

Keilnutenstossmaschine 25mm Hub H=65mm

Subject to change without notice.

M.T. srl

Via Casino Albini 480
 Tel. 0541/956034-957884
 Fax 0541/956341
 47842 S. GIOVANNI IN M. (RN)
 e-mail: mtma@tmarchetti.com
 http://www.tmmarchetti.com



NKM360-1-02