

**CUSCINETTI MAGGIORATI
PER LAVORAZIONI PESANTI**

Reinforced bearings for
heavy machining

Vergroesserte Lager fuer
schwerere Bearbeitungen

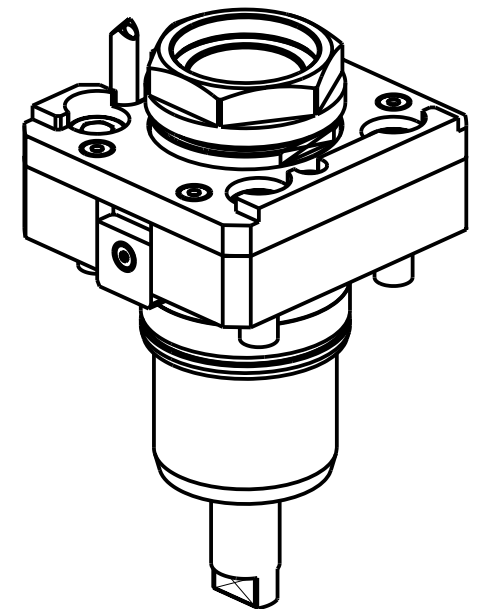
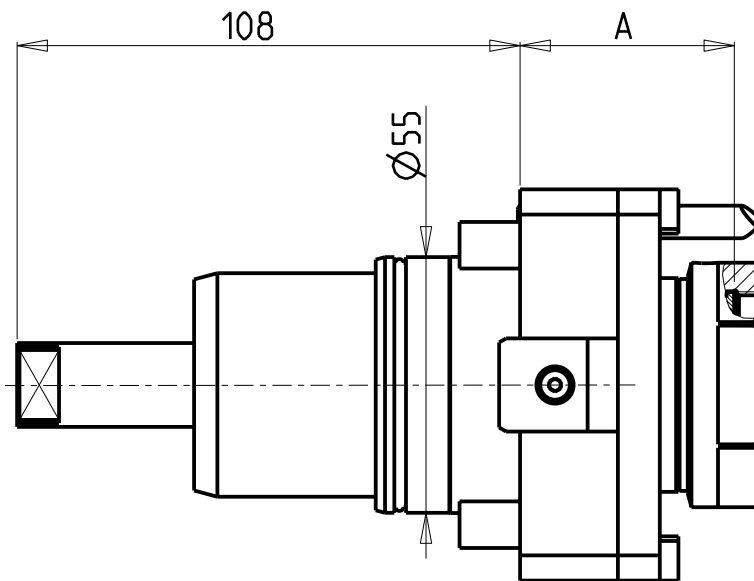
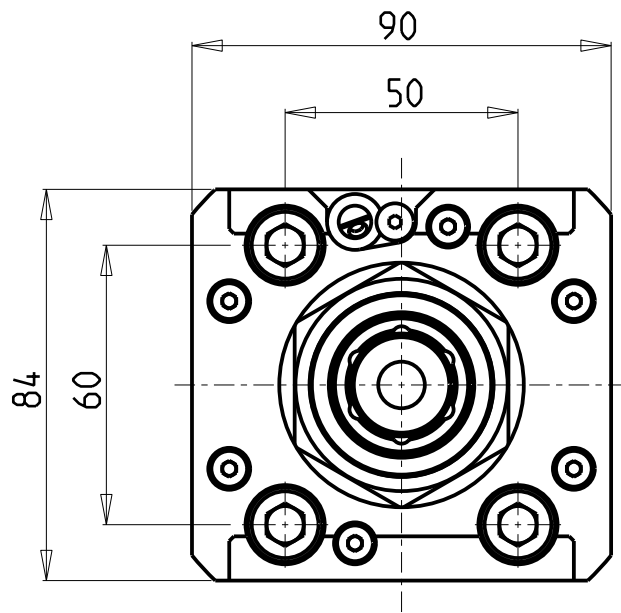

PER PORTAUTENSILI MODULARI MTSK-40 VEDI PAG. TBL300-1-40
FOR MTSK-40 QUIK CHANGE TOOLHOLDERS CLAMPINGS SEE PAGE TBL300-1-40
FUER MTSK-40 MODULARE WERKZEUGAUFNAHMEN SIEHE SEITE TBL300-1-40

Cod. MT	Mandrino Spindle Spindel	I	RPM	Coppia Max Max Torque Max Drehmoment	Lubrificazione int. Coolant through Innenkuhlung	Lubrificazione est. Ext. coolant Aussenkuehlung	A	CHIAVI NON INCLUSE Keys not included Schluessel nicht einbegriffen	
NKM1910140	MTSK-40	1:1	6000	50Nm	-	X	48	CHUB46	OKU0290009 •
NKM1350240	MTSK-40	1:1	6000	50Nm	P=30bar	X	57	CHUB46	OKU0650004 •

- Chiave inclusa
- Key included
- Schluessel inbegriffen

NAKAMURA-TOME

WT150/250 - WT15011/25011 - WTW150 - WTS150 - SUPER NTM3 - SUPER NTJ - SUPER NTJX - SC150/200/250 - SC20011 12/16 ST.
SC30011 16ST. - JX200/250 - NTY3 150/250 - TW10M/MY/MM/MMY/MMYY-TW20M/MY/MM/MMY/MMYY 16ST. - WY 150/250 - AS200 15/12 ST.

MODULO MOTORIZZATO RADIALE MTSK

Radial MTSK driven tool

Radial MTSK angetriebenes Werkzeug

Subject to change without notice.

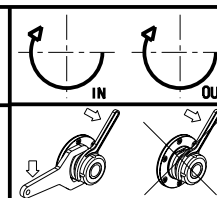

M.T. srl

Via Casino Albini 480
Tel. 0541/956034-957884
Fax 0541/956341
47842 S. GIOVANNI IN M. (RN)
e-mail: mtma@mtmarchetti.com
http://www.mtmarchetti.com



NKM020-2-00-K