

ATTENZIONE - ATTENTION - ACHTUNG

- Per lo smontaggio degli utensili utilizzare sempre la chiave di contrasto come indicato nel manuale d'uso.
- For disassembly of the tools use always the contrast key as mentioned in the user instructions.
- Fuer das Abmontieren der Werkzeuge immer den Gegenschlüssel benutzen wie in der Bedienungsanleitung erwaeht.

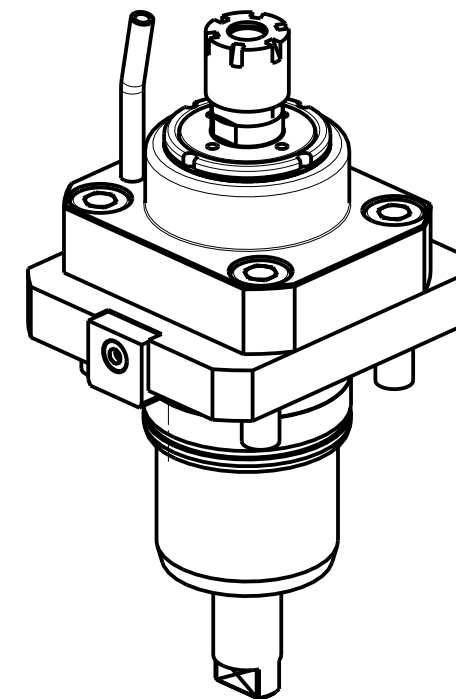

ATTENZIONE - ATTENTION - ACHTUNG

- PRIMA DI UTILIZZARE IL MOTORIZZATO CONSULTARE LE ISTRUZIONI ALLEGATE!
- BEFORE USING THE DRIVEN TOOL, PLEASE CHECK THE ENCLOSED INSTRUCTION SHEET!
- VOR DER BENUTZUNG DES ANGETRIEBENEN WERKZEUGES, DIE BEILIEGENDEN INSTRUKTIONEN DURCHLESEN!

Cod. MT	Mandrino Spindle Spindel	I	RPM	Coppia Max Max Torque Max Drehmoment	Lubrificazione est. Ext. coolant Aussenkuehlung	CHIAVI INCLUSE Keys included Schluessel einbegriffen	
NKM0040016	ER16	1:3	18000	10Nm	X	CHUB17	CHMNER16

NAKAMURA-TOME

WT150/250 - WT15011/25011 - WTW150 - WTS150 - SUPER NTM3 - SUPER NTJ - SUPER NTJX - SC150/200/250 - SC20011 12/16 ST. SC30011 16ST. - JX200/250 - NTY3 150/250 - TW10M/MY/MM/MMY/MMYY-TW20M/MY/MM/MMY/MMYY 16ST. - WY 150/250 - AS200 15/12 ST.

MODULO MOTORIZZATO RADIALE MOLTIPLICATO I=1:3

Radial geared-up I=1:3 driven tool

Radial angetriebenes Werkzeug uebersetzt I=1:3

Subject to change without notice.

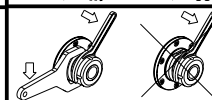
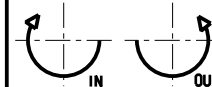

M.T. srl

Via Casino Albini 480
Tel. 0541/956034-957884
Fax 0541/956341
47842 S. GIOVANNI IN M. (RN)
e-mail: mtma@mtmarchetti.com.
http://www.mtmarchetti.com



NKM055-2-00