

ATTENZIONE - ATTENTION - ACHTUNG

- VERIFICARE LE MISURE DI INGOMBRO PER POSSIBILE INTERFERENZA SU ALCUNI MODELLI DI MACCHINE
- Please check the overall sizes for possible interferences on some machine models
- Bitte überprüfen sie das ausmass um mögliche interferenzen auf einigen maschinen modellen zu vermeiden

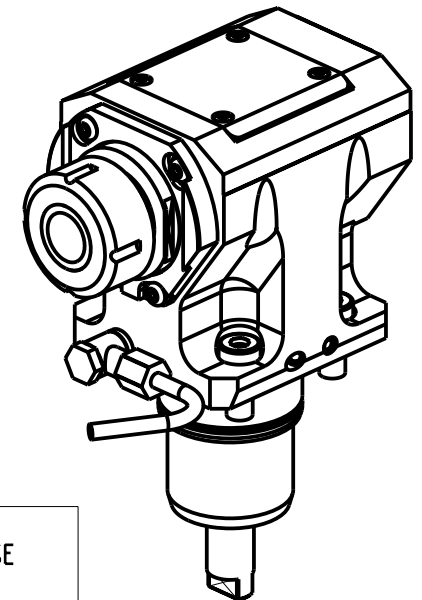

| Cod. MT | Mandrino Spindel Spindel | I | RPM | Coppia Max Max Torque Max Drehmoment | Reversibile lato mandrino/contromandrino Reversible sub/main spindle side Umkehrbare Spindel-seite/ Gegen-spindel-seite | Lubr.interna Coolant through Innenkuehlung | Lubr. esterna Ext. coolant Aussenkuehlung | A | B | CHIAVI NON INCLUSE Keys not included Schluessel nicht einbegriffen | |
|------------|--------------------------|-----|-------|--------------------------------------|---|--|---|------|------|--|------------|
| NKM2420132 | ER32 | 1:1 | 12000 | 50Nm | X | - | X | 88.7 | 56.5 | CHSTER32 | OKU0650004 |
| NKM2420140 | ER40 | 1:1 | 12000 | 50Nm | X | - | X | 99.2 | 56.5 | CHSTER40 | OKU0650004 |
| NKM2420232 | ER32 | 1:1 | 12000 | 50Nm | X | P=70bar | X | 88.7 | 67.5 | CHSTER32 | OKU0650004 |
| NKM2420240 | ER40 | 1:1 | 12000 | 50Nm | X | P=70bar | X | 99.2 | 67.5 | CHSTER40 | OKU0650004 |

NEW
NEW
NEW
NEW

- Chiave inclusa
- Key included
- Schluessel inbegriffen

NAKAMURA-TOME

WT250 - WT15011/25011 - WTW150 - WTS150 - SC150/200/250 - SC20011 12/16 ST. - SC30011 16ST. - JX200/250 SUPER NTJX - NTY3 150/250 - AS200 15ST.

MODULO MOTORIZZATO ASSIALE 12000 RPM H=75mm

Axial driven tool 12000 rpm H=75mm

Axial angetriebenes Werkzeug 12000 rpm H=75mm

Subject to change without notice.

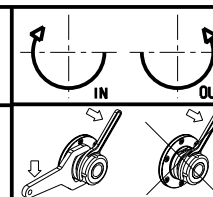

M.T. srl

Via Casino Albini 480
Tel. 0541/956034-957884
Fax 0541/956341
47842 S. GIOVANNI IN M. (RN)
e-mail: mtma@mtmarchetti.com
http://www.mtmarchetti.com



NKM150-2-23