

CUSCINETTI MAGGIORATI PER LAVORAZIONI PESANTI

Reinforced bearings for
heavy machining

Vergroesserte Lager fuer
schwerere Bearbeitungen

ATTENZIONE - ATTENTION - ACHTUNG

- Per lo smontaggio degli utensili utilizzare sempre la chiave di contrasto come indicato nel manuale d'uso.
- For disassembly of the tools use always the contrast key as mentioned in the user instructions.
- Fuer das Abmontieren der Werkzeuge immer den Gegenschlüssel benutzen wie in der Bedienungsanleitung erwaeht.

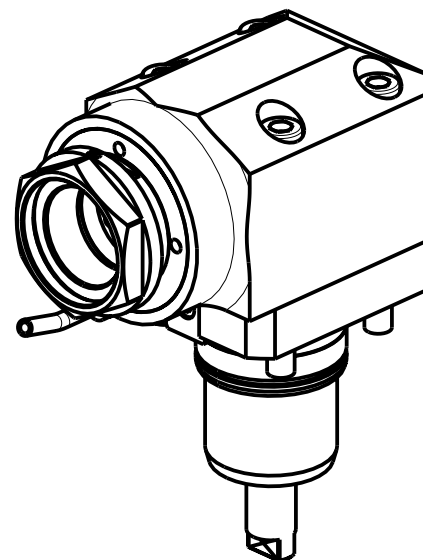

PER PORTAUTENSILI MODULARI MTSK-50 VEDI PAG. TBL300-1-50
FOR MTSK-50 QUICK CHANGE TOOLHOLDERS CLAMPINGS SEE PAGE TBL300-1-50
FUER MTSK-50 MODULARE WERKZEUGAUFNAHMEN SIEHE SEITE TBL300-1-50

Cod. MT	Mandrino Spindle Spindel	I	RPM	Coppia Max Max Torque Max Drehmoment	Reversibile lato mandrino/contromandrino Reversible sub/main spindle side Umkehrbare Spindel-seite/ Gegenspindel-seite	Lubr.interna Coolant through Innenkuehlung	Lubrificazione est. Ext. coolant Aussenkuehlung	B	CHIAVI NON INCLUSE Keys not included Schlüssel nicht einbegriffen	
NKM1000150	MTSK-50	1:1	6000	50Nm	X	-	X	48	CHUB46	CHUB55
NKM1000250	MTSK-50	1:1	6000	50Nm	X	P=70bar	X	58	CHUB46	CHUB55

NAKAMURA-TOME

WT150/250 - WT15011/25011 - WTW150 - WTS150 - SUPER NTM3 - SUPER NTJ - SC150/200/250 - SC20011 12/16 ST.
SC30011 16ST. - NTY3 150/250 - TW10M/MY/MM/MMY/MMYY-TW20M/MY/MM/MMY/MMYY 16ST. - WY150/250 - AS200 15/12 ST.

MODULO MOTORIZZATO ASSIALE MAGGIORATO MTSK H=55mm

Axial MTSK reinforced driven tool H=55mm

Axial MTSK angetriebenes Werkzeug vergroessert H=55mm

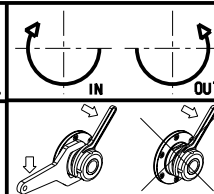

M.T. srl

Via Casino Albini 480
Tel. 0541/956034-957884
Fax 0541/956341

47842 S. GIOVANNI IN M. (RN)
e-mail: mtma@tmarchetti.com
http://www.tmmarchetti.com



NKM170-2-10-K

Subject to change without notice.

09/2024