

### ATTENZIONE - ATTENTION - ACHTUNG

- Per lo smontaggio degli utensili utilizzare sempre la chiave di contrasto come indicato nel manuale d'uso.
- For disassembly of the tools use always the contrast key as mentioned in the user instructions.
- Fuer das Abmontieren der Werkzeuge immer den Gegenschlüssel benutzen wie in der Bedienungsanleitung erwäehnt.

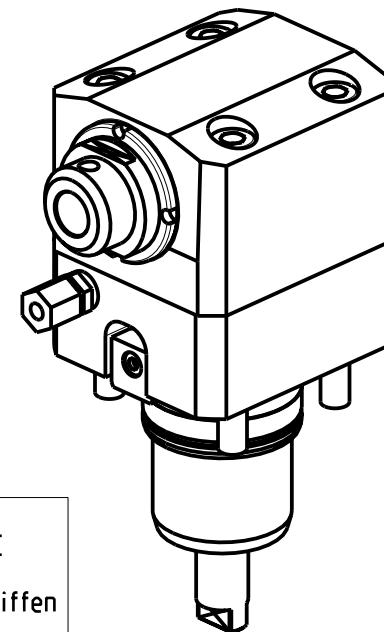

Cod. MT	Mandrino Spindle Spindel	I	RPM	Coppia Max Max Torque Max Drehmoment	Reversibile lato mandrino/contromandrino Reversible sub/main spindle side Umkehrbare Spindel-seite/ Gegenspindel-seite	Lubrificazione est. Ext. coolant Aussenkuehlung	A	A1	D	D1	CHIAVI NON INCLUSE Keys not included Schluesel nicht einbegriffen	
NKM0069125	ER25	1:1	6000	50Nm	X	X	-	80.44	-	-	CHUB36	CHSTER25
NKM0069108	WELDON 8	1:1	6000	50Nm	X	X	76.5	-	8	29	-	-
NKM0069110	WELDON 10	1:1	6000	50Nm	X	X	76.5	-	10	29	-	-
NKM0069112	WELDON 12	1:1	6000	50Nm	X	X	76.5	-	12	29	-	-
NKM0069116	WELDON 16	1:1	6000	50Nm	X	X	73.7	-	16	32	-	-

### NAKAMURA-TOME

WT250 - WT15011/25011 - WTW150 - WTS150 - SC150/200/250 - SC20011 12/16 ST. - SC30011 16ST. - JX200/250 - SUPER NTJX - NTY3 150/250

MODULO MOTORIZZATO ASSIALE PER POLIGONATURA INTERNA H=75mm

Axial driven tool for internal polygon-making H=75mm

Axial angetriebenes Werkzeug fuer interne Facettierung H=75mm

Subject to change without notice.

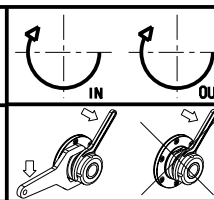

### M.T. srl

Via Casino Albini 480  
Tel. 0541/956034-957884

Fax 0541/956341

47842 S. GIOVANNI IN M. (RN)

e-mail: mtma@mtmarchetti.com

http://www.mtmarchetti.com



NKM230-2-20