

ATTENZIONE - ATTENTION - ACHTUNG

- Per lo smontaggio degli utensili utilizzare sempre la chiave di contrasto come indicato nel manuale d'uso.
- For disassembly of the tools use always the contrast key as mentioned in the user instructions.
- Fuer das Abmontieren der Werkzeuge immer den Gegenschlüssel benutzen wie in der Bedienungsanleitung erwaeht.

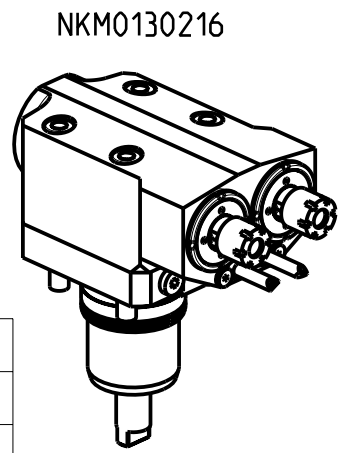
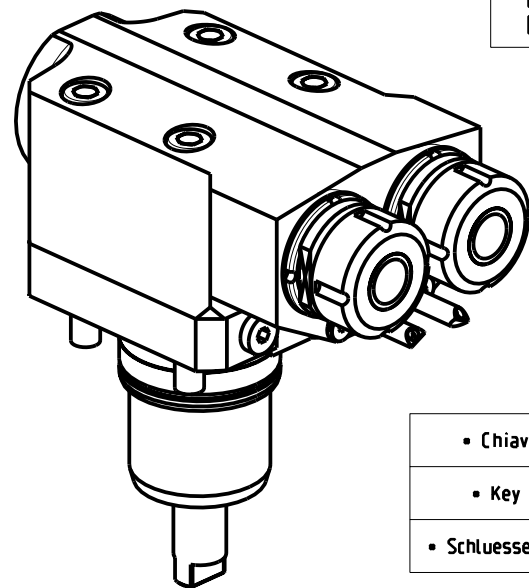

- Chiave inclusa
- Key included
- Schluessel inbegriffen

Cod. MT	Mandrino Spindel Spindel	I	RPM	Coppia Max Max Torque Max Drehmoment	Reversibile lato mandrino/contromandrino Reversible sub/main spindle side Umkehrbare Spindel-seite/ Gegenspindel-seite	Lubrificazione int. Coolant through Innenkuehlung	Lubrificazione est. Ext. coolant Aussenkuehlung	A	H	CHIAVI NON INCLUSE Keys not included Schluessel nicht einbegriffen	
NKM0130216	ER16	1:1	6000	30Nm	X	-	X	115.15	82	CHUB17	CHMNER16
NKM0130520	ERA20	1:1	6000	30Nm	X	P=70bar	X	116.15	87	MNLO210007	CHUB22 CHTAER20ZC*
NKM0130225	ER25	1:1	6000	30Nm	X	-	X	115.61	82	MNLO210007	CHSTER25
NKM0130425	ER25	1:1	6000	30Nm	X	P=70bar	X	128.11	87	MNLO210007	CHSTER25

NAKAMURA-TOME

WT150/250 - WT15011/25011 - WTW150 - WTS150 - SUPER NTM3 - SUPER NTJ - SC150/200/250 - SC20011 12/16 ST. SC30011 16ST. - NTY3 150/250 - TW10M/MY/MM/MMYY/MMYY-TW20M/MY/MM/MMYY/MMYY 16ST. - WY 150/250 - AS200MY 15/12 ST.

MODULO MOTORIZZATO ASSIALE 2 USCITE IN Y H=55mm
 Axial single side twin head driven tool in Y H=55mm
 Axial angetriebenes Werkzeug 2 Ausgaenge in Y H=55mm

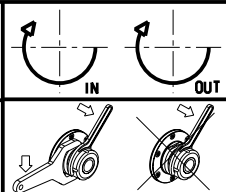

M.T. srl
 Via Casino Albini 480
 Tel. 0541/956034-957884
 Fax 0541/956341
 47842 S. GIOVANNI IN M. (RN)
 e-mail: mtma@mtmarchetti.com
 http://www.mtmarchetti.com



NKM260-2-10

Subject to change without notice.