

ATTENZIONE - ATTENTION - ACHTUNG

- Per lo smontaggio degli utensili utilizzare sempre la chiave di contrasto come indicato nel manuale d'uso.
- For disassembly of the tools use always the contrast key as mentioned in the user instructions.
- Fuer das Abmontieren der Werkzeuge immer den Gegenschlüssel benutzen wie in der Bedienungsanleitung erwäehnt.

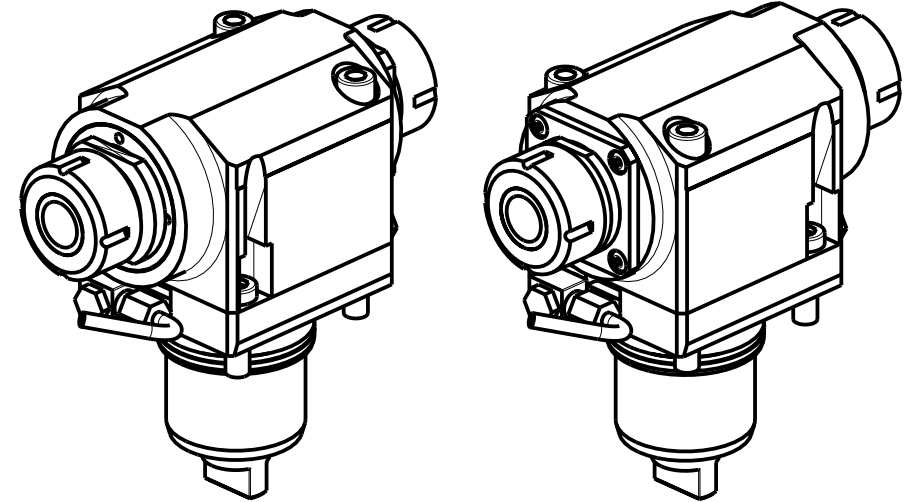
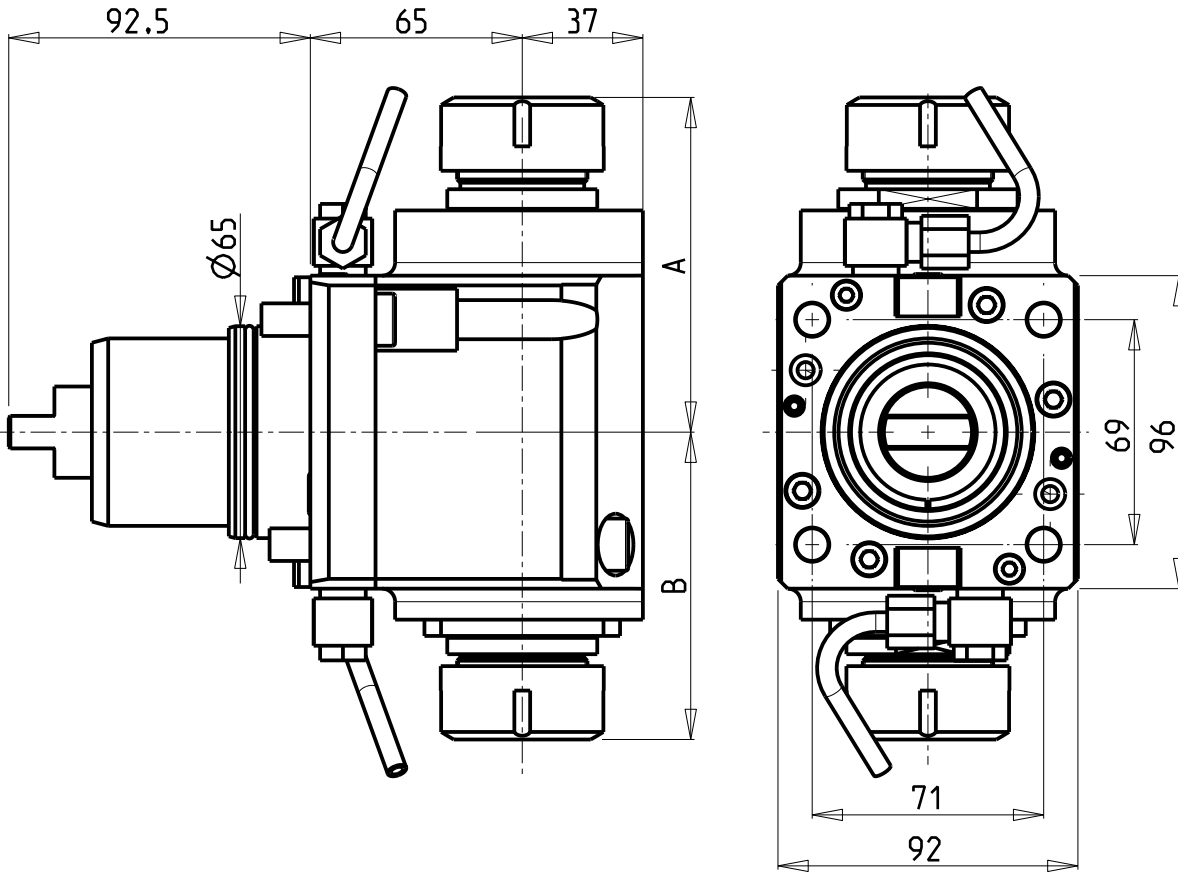

Cod. MT	Mandrino Spindle Spindel	I	RPM	Coppia Max Max Torque Max Drehmoment	Reversibile lato mandrino/contromandrino Reversible sub/main spindle side Umkehrbare Spindel-seite/ Gegenspindel-seite	Lubrificazione est. Ext. coolant Aussenkuehlung	A	B	CHIAVI NON INCLUSE Keys not included Schluessel nicht einbegriffen	
									CHSTER32	CHUB46
NKM0600232	ER32+ER32	1:1	6000	70Nm	X	X	102.66	94.26	CHSTER32	CHUB46
NKM0600240	ER40+ER40	1:1	6000	70Nm	X	X	106.16	107.16	CHSTER40	CHUB46

NAKAMURA-TOME

MOD: Super Mill WT150/WT150II/WY250/SC200L - SUPER NTY3 JUMBO

MODULO MOTORIZZATO ASSIALE BISPORGENTE H=65mm

Axial opposite face twin driven tool H=65mm

Axial angetriebenes Werkzeug halb vorspringend H=65mm

Subject to change without notice.

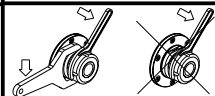

M.T. srl

Via Casino Albini 480
 Tel. 0541/956034-957884
 Fax 0541/956341
 47842 S. GIOVANNI IN M. (RN)
 e-mail: mtma@tmarchetti.com
 http://www.tmmarchetti.com



NKM240-4-10