

ATTENZIONE - ATTENTION - ACHTUNG

- VERIFICARE LE MISURE DI INGOMBRO PER POSSIBILE INTERFERENZA SU ALCUNI MODELLI DI MACCHINE
- Please check the overall sizes for possible interferences on some machine models
- Bitte überprüfen sie das ausmass um mögliche interferenzen auf einigen maschinen modellen zu vermeiden

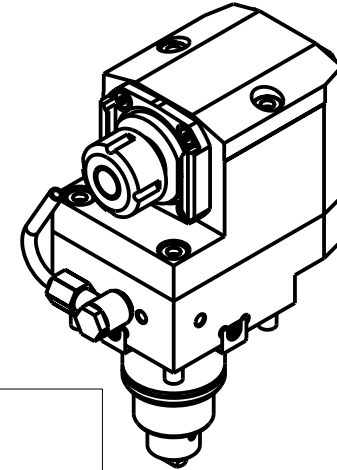

- Chiave inclusa
- Key included
- Schlüssel inbegriffen

CHIAVI NON INCLUDE  
Keys not included  
Schlüssel nicht einbegriffen

Cod. MT	Mandrino Spindle Spindel	I	RPM	Coppia Max Max Torque Max Drehmoment	Reversibile lato mandrino/contromandrino Reversible sub/main spindle side Umkehrbare Spindel-seite/ Gegenspindel-seite	Lubrificazione int. Coolant through Innenkuehlung	Lubrificazione est. Ext. coolant Ausseinkuehlung	A	B			
DW 02310120	ER20	1:1	6000	35Nm	X	-	X	41.16	73.5	-	CHSTER20	OKU0290009
DW 02310220	ER20	1:1	6000	35Nm	X	P=70bar	X	41.16	83.5	-	CHSTER20	OKU0290009
DW 02310320	ERA20	1:1	6000	35Nm	X	-	X	24.5	73.5	CHUB22	CHTAER20ZC	OKU0290009
DW 02310420	ERA20	1:1	6000	35Nm	X	P=70bar	X	24.5	83.5	CHUB22	CHTAER20ZC	OKU0290009
DW 02310125	ER25	1:1	6000	35Nm	X	-	X	42.16	73.5	-	CHSTER25	OKU0290009
DW 02310225	ER25	1:1	6000	35Nm	X	P=70bar	X	42.16	83.5	-	CHSTER25	OKU0290009
DW 02310325	ERA25	1:1	6000	35Nm	X	-	X	28.5	73.5	CHUB27	CHTAER25ZC	OKU0290009
DW 02310425	ERA25	1:1	6000	35Nm	X	P=70bar	X	28.5	83.5	CHUB27	CHTAER25ZC	OKU0290009

ROMI

MOD: GL 250Y/S

MODULO MOTORIZZATO ASSIALE ARRETRATO H=85mm

Axial rear-set driven tool H=85mm

Axial angetriebenes Werkzeug zurueckversetzt H=85mm

Subject to change without notice.

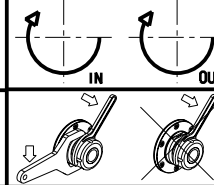

M.T. srl

Via Casino Albini 480  
Tel. 0541/956034-957884  
Fax 0541/956341  
47842 S. GIOVANNI IN M. (RN)  
e-mail: mtma@mtmarchetti.com  
http://www.mtmarchetti.com



ROM180-1-10

09/2024