

### ATTENZIONE - ATTENTION - ACHTUNG

- Con l'utensile orientato a  $\pm 90^\circ$ , non è possibile eseguire lavorazioni a centro-pezzo.
- It is not possible to make machining operations at the center of the part with the tool oriented at  $\pm 90^\circ$ .
- Mit einem Werkzeug  $\pm 90^\circ$  orientiert, ist es nicht möglich, Verarbeitungen an der Werkzeug-Mitte auszuführen.

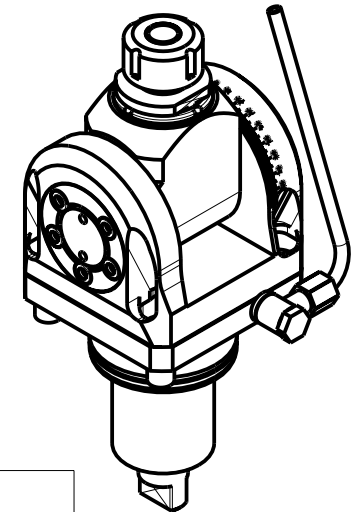

Cod. MT	Mandrino Spindle Spindel	I	RPM	Coppia Max Max Torque Max Drehmoment	Reversibile lato mandrino/contromandrino Reversible sub/main spindle side Umkehrbare Spindelseite/ Gegenspindelseite	Lubrificazione est. Ext. coolant Aussehenkuehlung	A	A1	D	L	CHIAVI INCLUSE Keys included Schlüssel inbegriffen		
											CH_VTCROCE_M08	CHUB36	CHESL10
DW 01920120	ER20	1:1	6000	40Nm	X	X	85.16	-	-	-	CHSTER20	CHUB36	CHESL10
DW 01920125	ER25	1:1	6000	40Nm	X	X	86.16	-	-	-	CHSTER25	CHUB36	CHESL10
DW 01920516	Ø16x17	1:1	6000	40Nm	X	X	-	65	16	17	CH_VTCROCE_M08	CHUB36	CHESL10
DW 01920522	Ø22x19	1:1	6000	40Nm	X	X	-	66	22	19	CH_VTCROCE_M10	CHUB36	CHESL10
DW 01920519	Ø3/4"x3/4"	1:1	6000	40Nm	X	X	-	65	3/4"	3/4"	CH_VTCROCE_M08	CHUB36	CHESL10

ROMI

MOD: GL 350M/Y/S

MODULO MOTORIZZATO ORIENTABILE  $\pm 90^\circ$  H=54mm

$\pm 90^\circ$  adjustable angle driven tool H=54mm

Angetriebenes Werkzeug schwenkbar  $\pm 90^\circ$  H=54mm

Subject to change without notice.

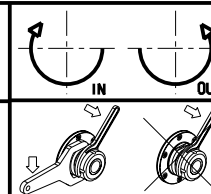

**M.T. srl**

Via Casino Albini 480  
Tel. 0541/956034-957884  
Fax 0541/956341  
47842 S. GIOVANNI IN M. (RN)  
e-mail: mtma@mtmarchetti.com  
http://www.mtmarchetti.com



ROM333-3-00