

### ATTENZIONE - ATTENTION - ACHTUNG

- VERIFICARE LE MISURE DI INGOMBRO PER POSSIBILE INTERFERENZA SU ALCUNI MODELLI DI MACCHINE
- Please check the overall sizes for possible interferences on some machine models
- Bitte überprüfen sie das ausmass um mögliche interferenzen auf einigen maschinen modellen zu vermeiden

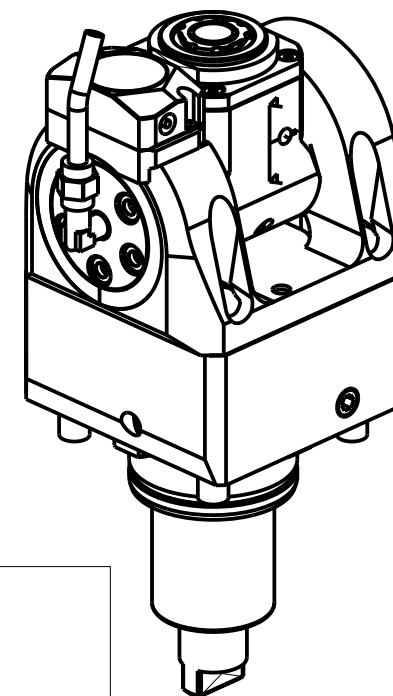

Cod. MT	Mandrino Spindle Spindel	I	RPM	Coppia Max Max Torque Max Drehmoment	Reversibile lato mandrino/contromandrino Reversible sub/main spindle side Umkehrbare Spindelsete/Gegenspindelsete	Lubrificazione int. Coolant through Innenkuehlung	Lubrificazione est. Ext. coolant Aussenkuehlung	CHIAVI INCLUSE Keys included Schluessel inbegriffen			
								CHUB22	CHUB36	CHTAER20ZC	CHESL08
DW00666120	ERA20	1:1	6000	30Nm	X	-	X	CHUB22	CHUB36	CHTAER20ZC	CHESL08
DW00666220	ERA20	1:1	6000	30Nm	X	P=70bar	X	CHUB22	CHUB36	CHTAER20ZC	CHESL08

ROMI

MOD: GL 300Y/S

MODULO MOTORIZZATO ORIENTABILE ±90° CON NONIO DIGITALE H=83mm  
 ±90° adjustable angle driven tool with digital display H=83mm  
 Angetriebenes Werkzeug schwenkbar ±90° mit digital display H=83mm

Subject to change without notice.

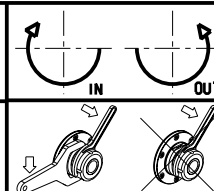

**M.T. srl**

Via Casino Albini 480  
 Tel. 0541/956034-957884  
 Fax 0541/956341  
 47842 S. GIOVANNI IN M. (RN)  
 e-mail: mtma@mtmarchetti.com  
 http://www.mtmarchetti.com



ROM335-2-11