

ATTENZIONE - ATTENTION - ACHTUNG

- VERIFICARE LE MISURE DI INGOMBRO PER POSSIBILE INTERFERENZA SU ALCUNI MODELLI DI MACCHINE
- Please check the overall sizes for possible interferences on some machine models
- Bitte überprüfen sie das ausmass um mögliche interferenzen auf einigen maschinen modellen zu vermeiden

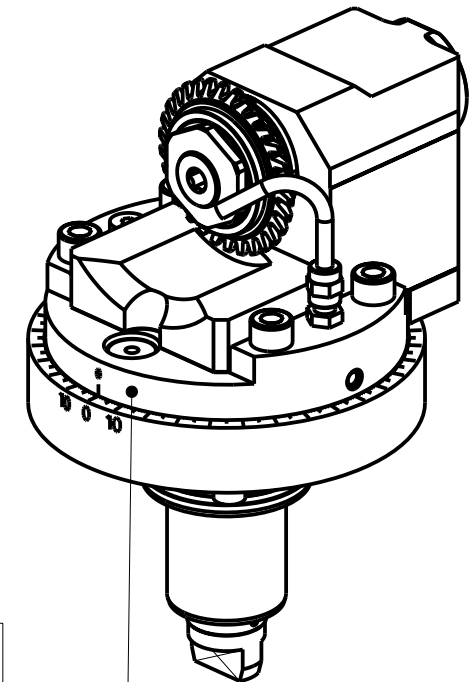
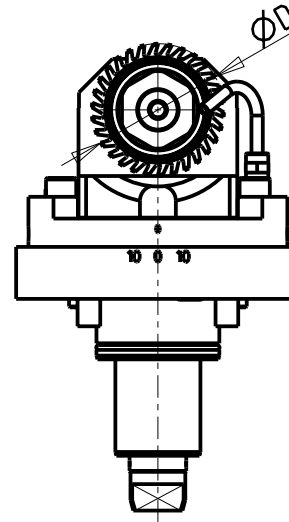
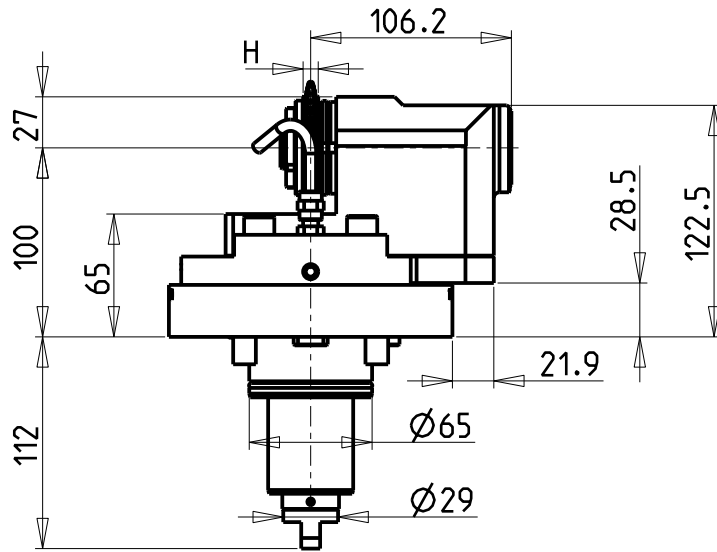
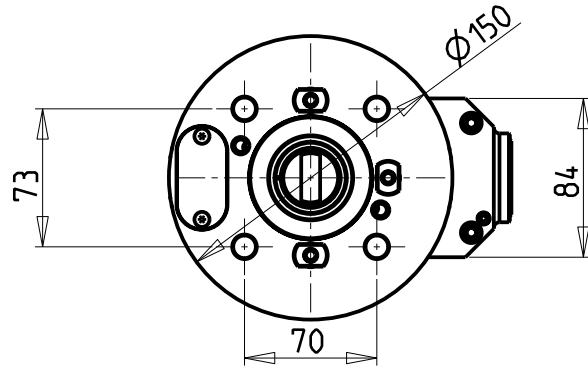

ORIENTABILE DI 360°

Cod. MT	Mandrino Spindle Spindel	I	RPM	Coppia Max Max Torque Max Drehmoment	Reversibile lato mandrino/contromandrino Reversible sub/main spindle side Umkehrbare Spindel-seite/ Gegenspindel-seite	Lubrificazione est. Ext. coolant Aussenkuehlung	ØD	H	CHIAVI INCLUSE Keys included Schluessel einbegriffen	
DW 02928022	Ø22x12	1:1	6000	50Nm	X	X	63-70-80	MAX 12	CHUB38	CHESL08
DW 02928125	Ø1"x12	1:1	6000	50Nm	X	X	63-70-80	MAX 12	CHUB38	CHESL08

ROMI

MOD: GL 350M/Y/S

MODULO MOTORIZZATO PER VITI SENZA FINE

Driven tool for worm screws

Angetriebenes Werkzeug für schrauben ohne ende

Subject to change without notice.

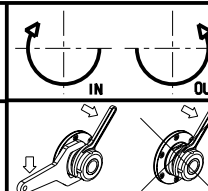

M.T. srl

Via Casino Albini 480  
Tel. 0541/956034-957884  
Fax 0541/956341  
47842 S. GIOVANNI IN M. (RN)  
e-mail: mtma@mtmarchetti.com  
http://www.mtmarchetti.com



ROM359-3-00