

Ø16
TOOL DIAMETER

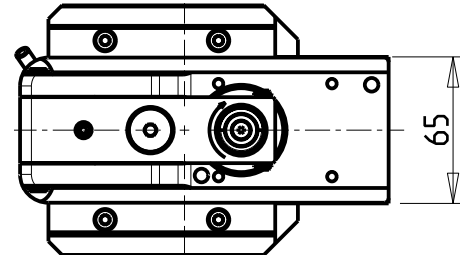
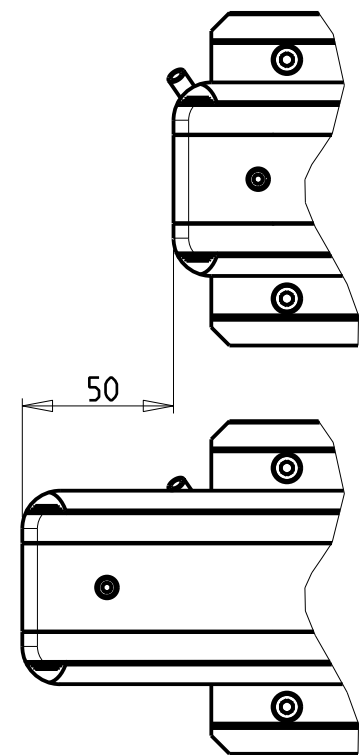
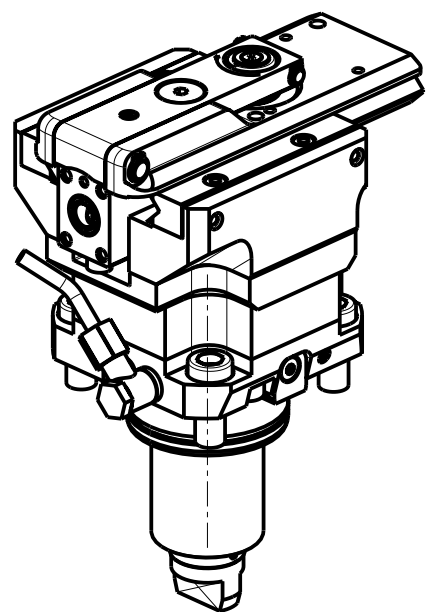

DOTAZIONI - SUPPLIED WITH - AUSSTATTUNG

N*1 Boccia di riduz. Ø16-Ø12 e N*1 Boccia di riduz. Ø16-Ø10
 N*1 Reduction bush Ø16-Ø12 and N*1 Reduction bush Ø16-Ø10
 N*1 Reduzierbuchsen Ø16-Ø12 und N*1 Reduzierbuchsen Ø16-Ø10

PER UTENSILI STOZZATORI VEDI PAG. TBL400-1-00
 FOR DRIVEN SLOTTING TOOL CUTTING-TOOLS SEE PAGE TBL400-1-00
 FÜR NUTENSTOSS-WERKZEUG SCHNEIDWERKZEUGE SIEHE SEITE TBL400-1-00

Cod. MT	I	RPM MAX	Reversibile lato mandrino/contromandrino Reversible sub/main spindle side Umkehrbare Spindel-seite/ Gegenspindel-seite	Lubr. esterna Ext. coolant Aussenkuehlung
DW 01530100	4:1	2000	X	X

ROMI
 MOD: GL 350M/Y/S
 MODULO MOTORIZZATO STOZZATORE CORSA 50mm H=85mm
 Slotting driven tool 50mm stroke H=85mm
 Keilnutenstossmaschine 50mm Hub H=85mm

M.T. srl
 Via Casino Albini 480
 Tel. 0541/956034-957884
 Fax 0541/956341
 47842 S. GIOVANNI IN M. (RN)
 e-mail: mtma@mtmarchetti.com
 http://www.mtmarchetti.com



ROM360-3-00

Subject to change without notice.