

## CUSCINETTI MAGGIORATI PER LAVORAZIONI PESANTI

Reinforced bearings for  
heavy machining

Vergroesserte Lager fuer  
schwerere Bearbeitungen

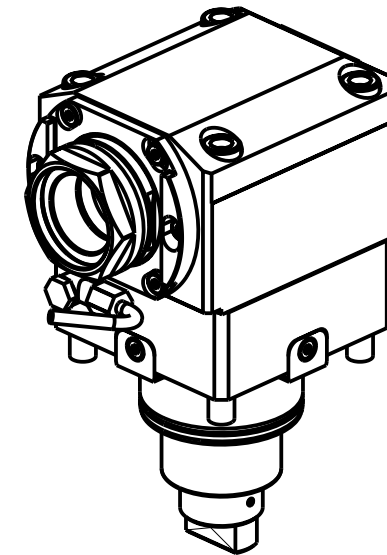
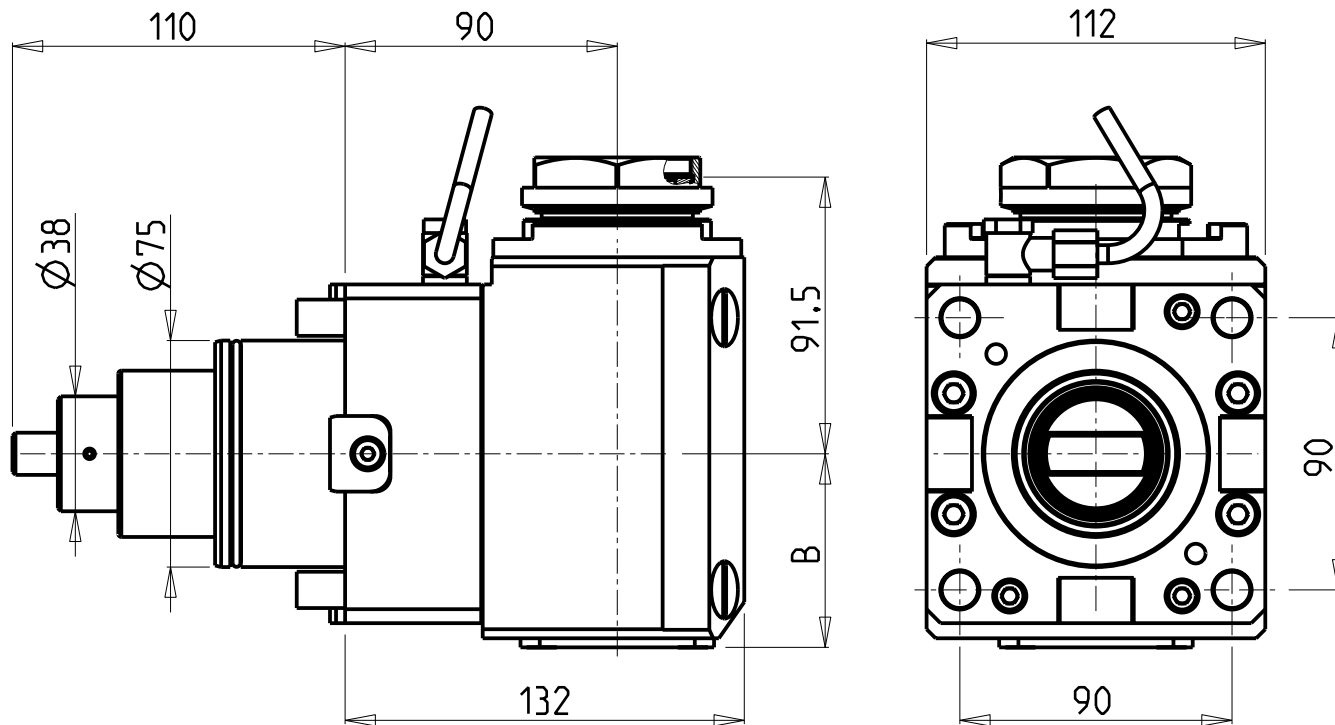

• Chiave inclusa

• Key included

• Schluessel inbegriffen

PER PORTAUTENSILI MODULARI MTSK-50 VEDI PAG. TBL300-1-50  
FOR MTSK-50 QUICK CHANGE TOOLHOLDERS CLAMPINGS SEE PAGE TBL300-1-50  
FUER MTSK-50 MODULARE WERKZEUGAUFNAHMEN SIEHE SEITE TBL300-1-50

Cod. MT	Mandrino Spindel Spindel	I	RPM	Coppia Max Max Torque Max Drehmoment	Reversibile lato mandrino/contromandrino Reversible sub/main spindle side Umkehrbare Spindel-seite/ Gegenspindel-seite	Lubr.interna Coolant through Innenkuehlung	Lubr.esterna Ext. coolant Aussenkuehlung	B	CHIAVI NON INCLUSE Keys not included Schluessel nicht einbegriffen	
DW 02150150	MTSK-50	1:1	6000	140Nm	X	-	X	64	CHUB55	OKU0430007 ▪
DW 02150250	MTSK-50	1:1	6000	140Nm	X	P=70bar	X	76.5	CHUB55	OKU0430007 ▪

SMART

MOD: NL4000/5000 M/LM/LY

MODULO MOTORIZZATO ASSIALE MAGGIORATO MTSK H=90mm

Axial MTSK reinforced driven tool H=90mm

Axial MTSK angetriebenes Werkzeug vergroessert H=90mm

Subject to change without notice.

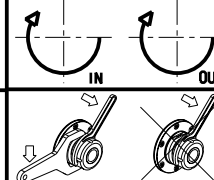

**M.T. srl**

Via Casino Albini 480  
Tel. 0541/956034-957884  
Fax 0541/956341  
47842 S. GIOVANNI IN M. (RN)  
e-mail: mtma@mtmarchetti.com  
http://www.mtmarchetti.com



SMA170-3-20-K

09/2024