

**CUSCINETTI MAGGIORATI  
PER LAVORAZIONI PESANTI**

Reinforced bearings for  
heavy machining

Vergroesserte Lager fuer  
schwerere Bearbeitungen

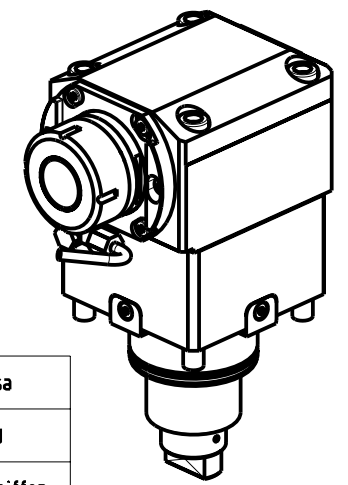

- Chiave inclusa
- Key included
- Schluessel inbegriffen

Cod. MT	Mandrino Spindle Spindel	I	RPM	Coppia Max Max Torque Max Drehmoment	Reversibile lato mandrino/contromandrino Reversible sub/main spindle side Umkehrbare Spindelseite/ Gegenspindelseite	Lubrificazione int. Coolant through Innenkuehlung	Lubrificazione est. Ext. coolant Aussenkuehlung	A	A1	A2	B	D	L	CHIAVI NON INCLUSE Keys not included Schluessel nicht einbegriffen	
DW 01340140	ER40	1:1	6000	140Nm	X	-	X	109.7	-	-	64	-	-	CHSTER40	OKU0430007 •
DW 01340240	ER40	1:1	6000	140Nm	X	P=70bar	X	109.7	-	-	76.5	-	-	CHSTER40	OKU0430007 •
DW 01340725	WELDON 25	1:1	6000	140Nm	X	-	X	-	109.5	-	64	-	-	-	-
DW 01340825	WELDON 25	1:1	6000	140Nm	X	P=70bar	X	-	109.5	-	76.5	-	-	-	-
DW 01340522	Ø22x19	1:1	6000	140Nm	X	-	X	-	-	89	64	22	19	CH_VTCROCE_M10 •	OKU0430007 •

**SMART**  
 MOD: NL4000/5000 M/LM/LY  
 MODULO MOTORIZZATO ASSIALE MAGGIORATO H=110mm  
 Axial reinforced driven tool H=110mm  
 Axial angetriebenes Werkzeug vergroessert H=110mm  
 Subject to change without notice.

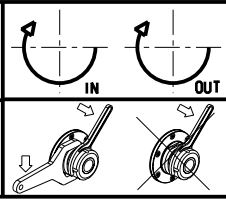

**M.T. srl**  
 Via Casino Albini 480  
 Tel. 0541/956034-957884  
 Fax 0541/956341  
 47842 S. GIOVANNI IN M. (RN)  
 e-mail: mtma@mtmarchetti.com  
 http://www.mtmarchetti.com

