

Ø16  
TOOL DIAMETER

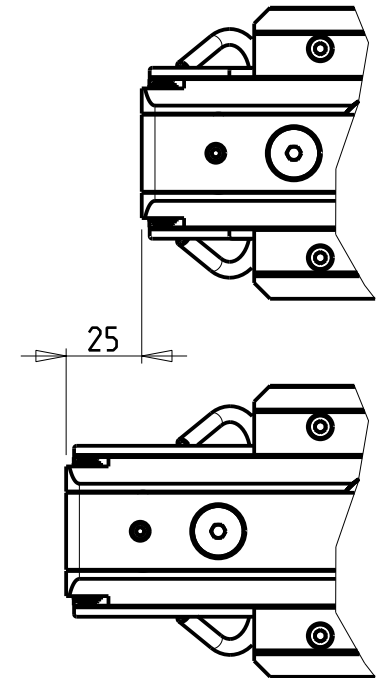
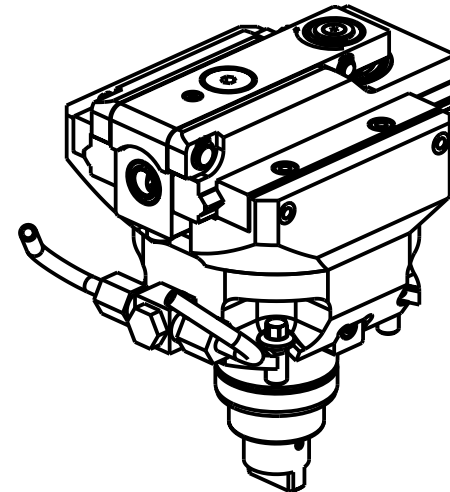

**DOTAZIONI - SUPPLIED WITH - AUSSTATTUNG**

N°1 Boccola di riduz. Ø16-Ø12 e N°1 Boccola di riduz. Ø16-Ø10  
 N°1 Reduction bush Ø16-Ø12 and N°1 Reduction bush Ø16-Ø10  
 N°1 Reduzierbuchsen Ø16-Ø12 und N°1 Reduzierbuchsen Ø16-Ø10

PER UTENSILI STOZZATORI VEDI PAG. TBL400-1-00  
 FOR DRIVEN SLOTTING TOOL CUTTING-TOOLS SEE PAGE TBL400-1-00  
 FÜR NUTENSTOSS-WERKZEUG SCHNEIDWERKZEUGE SIEHE SEITE TBL400-1-00

Cod. MT	I	RPM MAX	Reversibile lato mandrino/contromandrino Reversible sub/main spindle side Umkehrbare Spindel-seite/ Gegenspindel-seite	Lubr. esterna Ext. coolant Aussehenkuehlung
SPN0060200	4:1	2400	X	X

**SPINNER**

MOD: TC300 12ST. - TC600 16ST. - TTC300 12 ST. - TTS42/65 (BMT45 SHORT) - MICROTURNS 36/52

MODULO MOTORIZZATO STOZZATORE CORSA 25mm H=75mm

Slotting driven tool 25mm stroke H=75mm

Keilnutenstossmaschine 25mm Hub H=75mm

Subject to change without notice.

**M.T. srl**

Via Casino Albini 480  
 Tel. 0541/956034-957884  
 Fax 0541/956341  
 47842 S. GIOVANNI IN M. (RN)  
 e-mail: mtma@mtmarchetti.com  
 http://www.mtmarchetti.com



SPN360-1-02