

- Chiave inclusa
- Key included
- Schluessel inbegriffen

### ATTENZIONE - ATTENTION - ACHTUNG

- Per lo smontaggio degli utensili utilizzare sempre la chiave di contrasto come indicato nel manuale d'uso.
- For disassembly of the tools use always the contrast key as mentioned in the user instructions.
- Fuer das Abmontieren der Werkzeuge immer den Gegenschlüssel benutzen wie in der Bedienungsanleitung erwaeht.

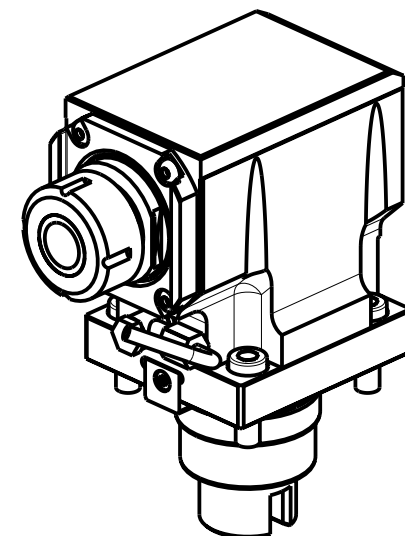

Cod. MT	Cod. TAKISAWA	Mandrino Spindle Spindel	I	RPM	Coppia Max Max Torque Max Drehmoment	Lubr.interna Coolant through Innenkuehlung	Lubr.esterna Ext. coolant AusSENkuehlung	A	A1	D	L	B	CHIAVI NON INCLUDE Keys not included Schluessel nicht einbegriffen	
TKW 0110132	HF23001-000Z	ER32	1:1	6000	65Nm	-	X	108.7	-	-	-	54.5	CHSTER32	OKU0650004 •
TKW 0110232	-	ER32	1:1	6000	65Nm	P=70bar	X	108.7	-	-	-	67	CHSTER32	OKU0650004 •
TKW 0110527	-	Ø27x21	1:1	6000	65Nm	-	X	-	85	27	21	54.5	CH_VTCROCE_M12 •	OKU0650004 •

### TAKISAWA

MOD: EX308/310/508/510/708/710/910 - TC350MC - TT350 MC - NEX108/110/908/910 - LA200/250/300 M/Y - LA250YS 15ST.  
FX-800 - VTL450M - EX2000M/Y - LX2500/3000M/Y - NX-2000 M/MS/Y/YS 12ST.

### MODULO MOTORIZZATO ASSIALE

Axial driven tool

Axial angetriebenes Werkzeug

Subject to change without notice.

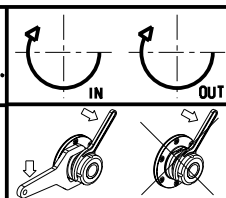

### M.T. srl

Via Casino Albini 480  
Tel. 0541/956034-957884  
Fax 0541/956341  
47842 S. GIOVANNI IN M. (RN)  
e-mail: mtma@tmarchetti.com  
http://www.tmmarchetti.com



TKW 150-2-10