

ATTENZIONE - ATTENTION - ACHTUNG

- Per lo smontaggio degli utensili utilizzare sempre la chiave di contrasto come indicato nel manuale d'uso.
- For disassembly of the tools use always the contrast key as mentioned in the user instructions.
- Fuer das Abmontieren der Werkzeuge immer den Gegenschlüssel benutzen wie in der Bedienungsanleitung erwäehnt.

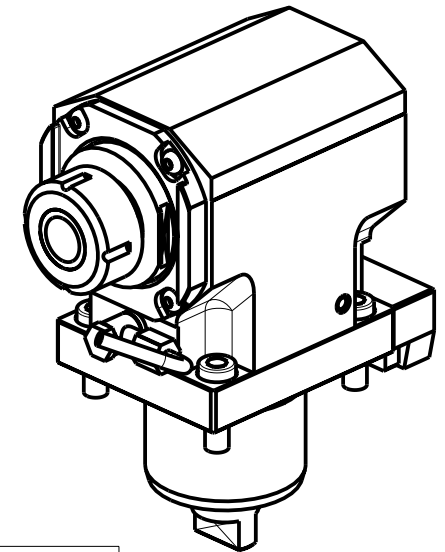

- Chiave inclusa
- Key included
- Schluessel inbegriffen

Cod. MT	Cod. TAKISAWA	Mandrino Spindel Spindel	I	RPM	Coppia Max Max Torque Max Drehmoment	Lubr.interna Coolant through Innenkuehlung	Lubr.esterna Ext. coolant Aussenkuehlung	A	B	CHIAVI NON INCLUSE Keys not included Schluessel nicht einbegriffen	
TKW 0180132	GM81999-441	ER32	1:1	6000	60Nm	-	X	96.7	63	CHSTER32	OKU0430007 ▪
TKW 0180140	-	ER40	1:1	6000	60Nm	-	X	99.7	63	CHSTER40	OKU0430007 ▪
TKW 0180232	-	ER32	1:1	6000	60Nm	P=70bar	X	96.7	79.5	CHSTER32	OKU0430007 ▪
TKW 0180240	-	ER40	1:1	6000	60Nm	P=70bar	X	99.7	79.5	CHSTER40	OKU0430007 ▪

TAKISAWA
MOD: TY2000Y/YS/CS

MODULO MOTORIZZATO ASSIALE
Axial driven tool
Axial angetriebenes Werkzeug

Subject to change without notice.

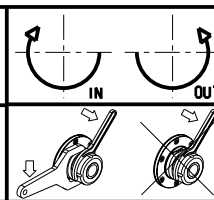

M.T. srl
Via Casino Albini 480
Tel. 0541/956034-957884
Fax 0541/956341
47842 S. GIOVANNI IN M. (RN)
e-mail: mtma@mtmarchetti.com
http://www.mtmarchetti.com



TKW 150-5-10