

ATTENZIONE - ATTENTION - ACHTUNG

- Per lo smontaggio degli utensili utilizzare sempre la chiave di contrasto come indicato nel manuale d'uso.
- For disassembly of the tools use always the contrast key as mentioned in the user instructions.
- Fuer das Abmontieren der Werkzeuge immer den Gegenschlüssel benutzen wie in der Bedienungsanleitung erwäehnt.

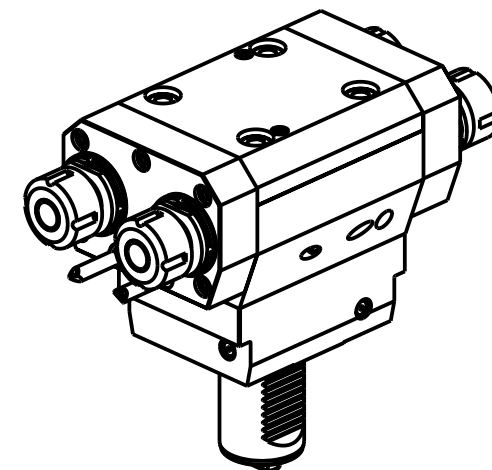
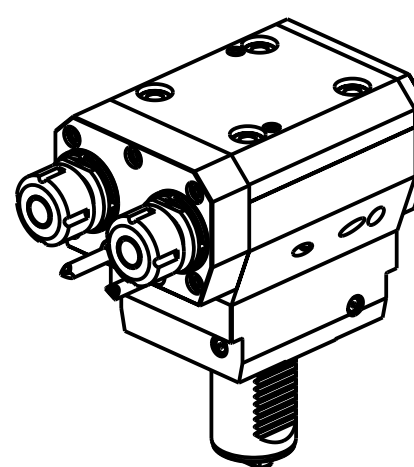

Cod. MT	Mandrino Spindle Spindel	I	RPM	Coppia Max Max Torque Max Drehmoment	Reversibile lato mandrino/contromandrino Reversible sub/main spindle side Umkehrbare Spindel-seite/ Gegenspindel-seite	N°Utensili N°Tools N°Werkzeuge	Lubr.esterna Ext. coolant Aussehenkuehlung	A	B	CHIAVI NON INCLUDE Keys not included Schluessel nicht einbegriffen	
TKW 0990120	ER20	1:1	6000	40Nm	X	2	X	113.2	-	CHUB32	CHSTER20
TKW 0990220	ER20+ER20	1:1	6000	40Nm	X	2+2	X	113.2	113.2	CHUB32	CHSTER20

TAKISAWA
MOD: TMM200/250 - TNR200

MODULO MOTORIZZATO ASSIALE 2/4 USCITE IN Y VDI40
Axial multiple 2/4 outlet driven tool in Y VDI40
Axial angetriebenes Mehrspindel-Werkzeug 2/4 Ausgaenge in Y VDI40

Subject to change without notice.

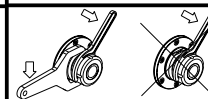

M.T. srl

Via Casino Albini 480
Tel. 0541/956034-957884
Fax 0541/956341
47842 S. GIOVANNI IN M. (RN)
e-mail: mtma@mtmarchetti.com
http://www.mtmarchetti.com



TKW 268-3-10