

### ATTENZIONE - ATTENTION - ACHTUNG

- VERIFICARE LE MISURE DI INGOMBRO PER POSSIBILE INTERFERENZA SU ALCUNI MODELLI DI MACCHINE
- Please check the overall sizes for possible interferences on some machine models
- Bitte überprüfen sie das ausmass um mögliche interferenzen auf einigen maschinen modellen zu vermeiden

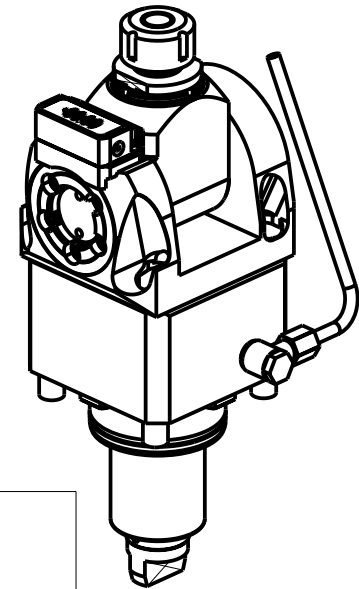

| Cod. MT     | Mandrino<br>Spindle<br>Spindel | I   | RPM  | Coppia Max<br>Max Torque<br>Max Drehmoment | Reversibile lato<br>mandrino/contromandrino<br>Reversible sub/main<br>spindle side Umkehrbare<br>Spindel-seite/<br>Gegenspindel-seite | Lubrificazione est.<br>Ext. coolant<br>Aussehenkuehlung | A     | A1 | D    | L    | CHIAVI INCLUSE<br>Keys included<br>Schlüssel inbegriffen |        |         |
|-------------|--------------------------------|-----|------|--|---|---|-------|----|------|------|--|--------|---------|
|             |                                |     |      |  |   |   |       |    |      |      | CH_VTCROCE_M08   | CHUB36 | CHESL10 |
| DW 01860120 | ER20                           | 1:1 | 6000 | 40Nm                                       | X   | X   | 85.16 | -  | -    | -    | CHSTER20   | CHUB36 | CHESL10 |
| DW 01860125 | ER25                           | 1:1 | 6000 | 40Nm                                       | X   | X   | 86.16 | -  | -    | -    | CHSTER25   | CHUB36 | CHESL10 |
| DW 01860516 | $\varnothing 16 \times 17$     | 1:1 | 6000 | 40Nm                                       | X   | X   | -     | 65 | 16   | 17   | CH_VTCROCE_M08   | CHUB36 | CHESL10 |
| DW 01860522 | $\varnothing 22 \times 19$     | 1:1 | 6000 | 40Nm                                       | X   | X   | -     | 66 | 22   | 19   | CH_VTCROCE_M10   | CHUB36 | CHESL10 |
| DW 01860519 | $\varnothing 3/4 \times 3/4$   | 1:1 | 6000 | 40Nm                                       | X   | X   | -     | 65 | 3/4" | 3/4" | CH_VTCROCE_M08   | CHUB36 | CHESL10 |

TAKISAWA

MOD: NX-2500 12ST./15ST. (BMT65)

MODULO MOTORIZZATO ORIENTABILE  $\pm 90^\circ$  CON NONIO DIGITALE H=100mm

$\pm 90^\circ$  adjustable angle driven tool with digital display H=100mm

Angetriebenes Werkzeug schwenkbar  $\pm 90^\circ$  mit digital display H=100mm

Subject to change without notice.

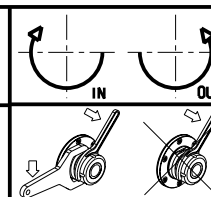

**M.T. srl**

Via Casino Albini 480  
Tel. 0541/956034-957884  
Fax 0541/956341  
47842 S. GIOVANNI IN M. (RN)  
e-mail: mtma@mtmarchetti.com  
http://www.mtmarchetti.com



TKW 333-10-11