

ATTENZIONE - ATTENTION - ACHTUNG

- Per lo smontaggio degli utensili utilizzare sempre la chiave di contrasto come indicato nel manuale d'uso.
- For disassembly of the tools use always the contrast key as mentioned in the user instructions.
- Fuer das Abmontieren der Werkzeuge immer den Gegenschlüssel benutzen wie in der Bedienungsanleitung erwaehnt.

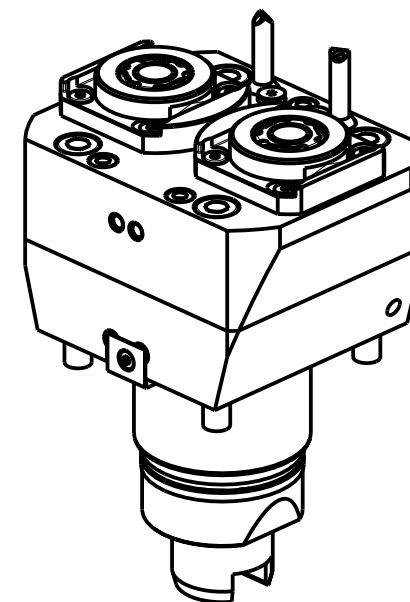

- Chiave inclusa
- Key included
- Schlüssel inbegriffen

| Cod. MT | Mandrino Spindle Spindel | I | RPM | Coppia Max Max Torque Max Drehmoment | Lubrificazione int. Coolant through Innenkuehlung | Lubrificazione est. Ext. coolant Aussenkuehlung | CHIAVI NON INCLUSE Keys not included Schlüssel nicht einbegriffen | | |
|------------|--------------------------|-----|------|--------------------------------------|---------------------------------------------------|-------------------------------------------------|-------------------------------------------------------------------------|------------|------------|
| TSM0110120 | ERA20 | 1:1 | 5000 | 50Nm | - | X | CHUB22 | CHTAER20ZC | OKU0290009 |
| TSM0110220 | ERA20 | 1:1 | 5000 | 50Nm | P=70bar | X | CHUB22 | CHTAER20ZC | OKU0290009 |

TSUGAMI
MOD: M06 - M08

MODULO MOTORIZZATO RADIALE 2 USCITE IN Y
Radial single side twin head driven tool in Y
Radial angetriebenes Werkzeug 2 Ausgaenge in Y

Subject to change without notice.

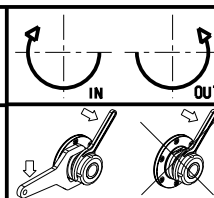

M.T. srl
Via Casino Albini 480
Tel. 0541/956034-957884
Fax 0541/956341
47842 S. GIOVANNI IN M. (RN)
e-mail: mtma@mtmarchetti.com
http://www.mtmarchetti.com

