

**ATTENZIONE - ATTENTION - ACHTUNG**

- Per lo smontaggio degli utensili utilizzare sempre la chiave di contrasto come indicato nel manuale d'uso.
- For disassembly of the tools use always the contrast key as mentioned in the user instructions.
- Fuer das Abmontieren der Werkzeuge immer den Gegenschlüssel benutzen wie in der Bedienungsanleitung erwaeht.

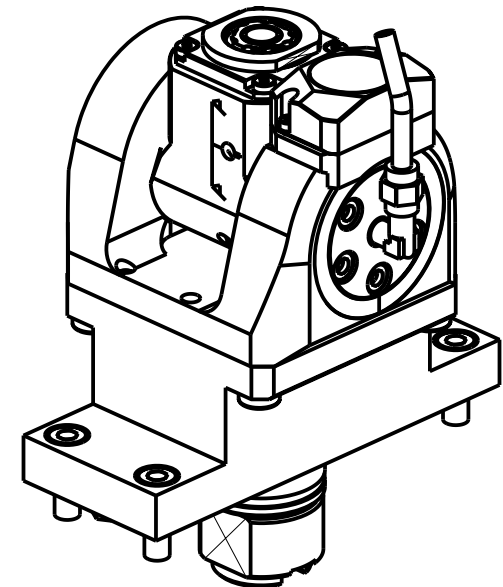

| Cod. MT    | Mandrino Spindle Spindel | i   | RPM MAX | Coppia Max Max Torque Max Drehmoment | Lubrificazione int. Coolant through Innenkuehlung | Lubrificazione est. Ext. coolant Aussenkuehlung | CHIAVI INCLUDE Keys included Schluessel inbegriffen |        |            |
|------------|--------------------------|-----|---------|--------------------------------------|---|---|---|--------|------------|
| TSM0145316 | ERA16                    | 1:2 | 12000   | 8Nm                                  | -   | X   | CHUB19_SP3  | CHUB32 | CHTAER16ZC |
| TSM0145416 | ERA16                    | 1:2 | 12000   | 8Nm                                  | P=70bar   | X   | CHUB19_SP3  | CHUB32 | CHTAER16ZC |

**TSUGAMI**  
MOD: B038 - BH20/38

MODULO MOTORIZZATO ORIENTABILE +/-90° MOLTIPLICATO I=1:2 CON NONIO DIGITALE  
 +/-90° adjustable angle driven tool geared-up I=1:2 with digital display  
 Angetriebenes Werkzeug schwenkbar +/-90° uebersetzt I=1:2 mit digital display

Subject to change without notice.

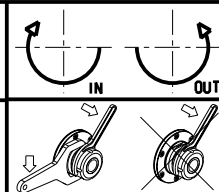

**M.T. srl**  
 Via Casino Albini 480  
 Tel. 0541/956034-957884  
 Fax 0541/956341  
 47842 S. GIOVANNI IN M. (RN)  
 e-mail: mtma@mtmarchetti.com  
 http://www.mtmarchetti.com



TSM336-4-01