

ATTENZIONE - ATTENTION - ACHTUNG

- Per lo smontaggio degli utensili utilizzare sempre la chiave di contrasto come indicato nel manuale d'uso.
- For disassembly of the tools use always the contrast key as mentioned in the user instructions.
- Fuer das Abmontieren der Werkzeuge immer den Gegenschlüssel benutzen wie in der Bedienungsanleitung erwäehnt.

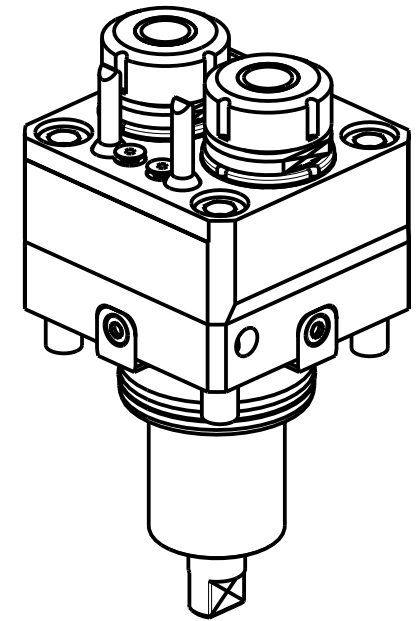

| Cod. MT | Mandrino Spindle Spindel | I | RPM | Coppia Max Max Torque Max Drehmoment | Lubrificazione est. Ext. coolant Aussehenkuehlung | A | CHIAVI NON INCLUSE Keys not included Schlüssel nicht einbegriffen | |
|-------------|--------------------------|-----|------|--------------------------------------|---|------|---|------------|
| DW 00540216 | ER16 | 1:1 | 6000 | 30Nm | X | 84.5 | CHMNER16 | CHUB17 |
| DW 00540225 | ER25 | 1:1 | 6000 | 30Nm | X | 85 | CHSTER25 | MNLO210007 |

VICTOR
 MOD: VTURN-A26 CM/SCM/YCM/YSCM
 MODULO MOTORIZZATO RADIALE 2 USCITE IN Y
 Radial single side twin head driven tool in Y
 Radial angetriebenes Werkzeug 2 Ausgaenge in Y
 Subject to change without notice.

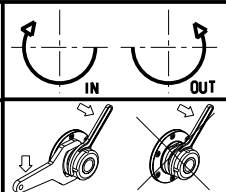

M.T. srl
 Via Casino Albini 480
 Tel. 0541/956034-957884
 Fax 0541/956341
 47842 S. GIOVANNI IN M. (RN)
 e-mail: mtma@mtmarchetti.com
 http://www.mtmarchetti.com

