

ATTENZIONE - ATTENTION - ACHTUNG

- VERIFICARE LE MISURE DI INGOMBRO PER POSSIBILE INTERFERENZA SU ALCUNI MODELLI DI MACCHINE
- Please check the overall sizes for possible interferences on some machine models
- Bitte überprüfen sie das ausmass um mögliche interferenzen auf einigen maschinen modellen zu vermeiden

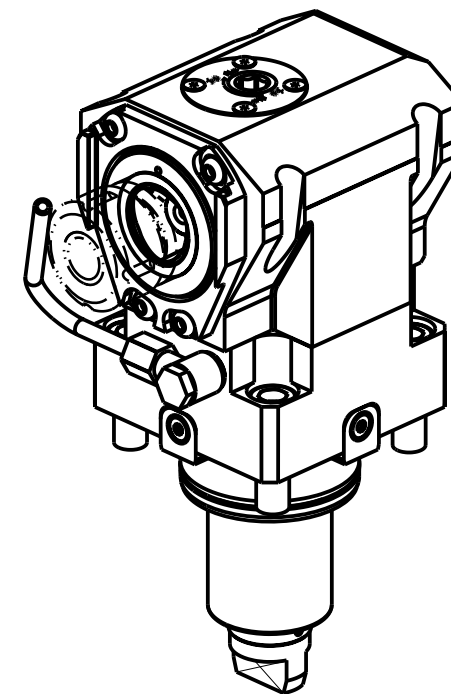

ATTENZIONE: Non si monta su macchina VTURN-S26 CM

WARNING: This tool can not be mounted on VTURN-S26 CM

ACHTUNG: Werkzeug darf nicht auf VTURN-S26 CM montiert werden

Cod. MT	TAGLIA Size Masse	I	RPM	Coppia Max Max Torque Max Drehmoment	Reversibile lato mandrino/contromandrino Reversible sub/main spindle side Umkehrbare Spindel-seite/ Gegenspindel-seite	Lubr.interna Coolant through Innenkuehlung	Lubr.esterna Ext. coolant Aussenkuehlung	B
DW03120140	C4	1:1	6000	100Nm	X	-	X	55.5
# DW03120240	C4	1:1	6000	100Nm	X	P=70bar	X	66.5

VICTOR

MOD: VTURN-A26 CM/SCM/YCM/YSCM - VTURN-S26 CM

MODULO MOTORIZZATO ASSIALE MT CAPTO H=95mm

Axial driven tool MT CAPTO H=95mm

Axial angetriebenes Werkzeug MT CAPTO H=95mm

Subject to change without notice.

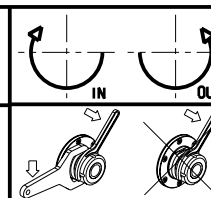

M.T. srl

Via Casino Albini 480
Tel. 0541/956034-957884
Fax 0541/956341
47842 S. GIOVANNI IN M. (RN)
e-mail: mtma@mtmarchetti.com
http://www.mtmarchetti.com



VCT150-B-42