

ATTENZIONE - ATTENTION - ACHTUNG

- Per lo smontaggio degli utensili utilizzare sempre la chiave di contrasto come indicato nel manuale d'uso.
- For disassembly of the tools use always the contrast key as mentioned in the user instructions.
- Fuer das Abmontieren der Werkzeuge immer den Gegenschlüssel benutzen wie in der Bedienungsanleitung erwäehnt.

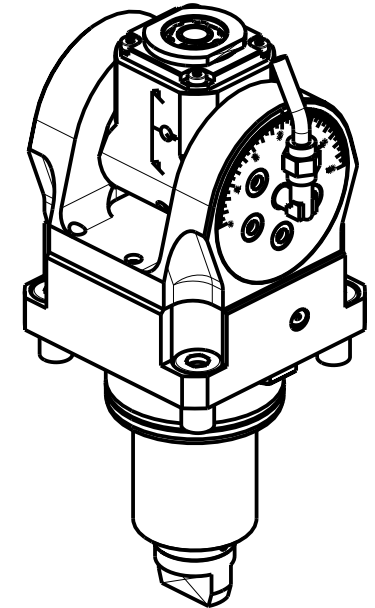

| Cod. MT | Mandrino Spindle Spindel | i | RPM | Coppia Max Max Torque Max Drehmoment | Reversibile lato mandrino/contromandrino Reversible sub/main spindle side Umkehrbare Spindel-seite/ Gegenspindel-seite | Lubrificazione int. Coolant through Innenkuehlung | Lubrificazione est. Ext. coolant Aussenkuehlung | CHIAVI INCLUDE Keys included Schluessel inbegriffen | | | |
|------------|--------------------------|-----|-------|--------------------------------------|--|---|---|---|--------|------------|---------|
| | | | | | | | | CHUB19_SP3 | CHUB32 | CHTAER16ZC | CHESL08 |
| DW01940316 | ERA16 | 1:2 | 12000 | 8Nm | X | - | X | CHUB19_SP3 | CHUB32 | CHTAER16ZC | CHESL08 |
| DW01940416 | ERA16 | 1:2 | 12000 | 8Nm | X | P=70bar | X | CHUB19_SP3 | CHUB32 | CHTAER16ZC | CHESL08 |

YCM
 MOD: BTX250SY - NT2000/2500 12 STAZIONI

MODULO MOTORIZZATO ORIENTABILE ±90° MOLTIPLICATO i=1:2 H=72mm
 ±90° adjustable angle driven tool geared-up i=1:2 H=72mm
 Angetriebenes Werkzeug schwenkbar ±90° uebersetzt i=1:2 H=72mm

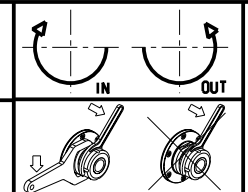

M.T. srl
 Via Casino Albini 480
 Tel. 0541/956034-957884
 Fax 0541/956341
 47842 S. GIOVANNI IN M. (RN)
 e-mail: mtma@mtmarchetti.com
 http://www.mtmarchetti.com

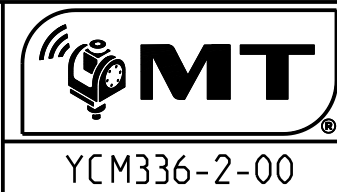

Subject to change without notice.